

A. WOOD. Machine for Grinding Pulleys.

Patented June 22, 1875.

No. 164,897.

Fig. 1.

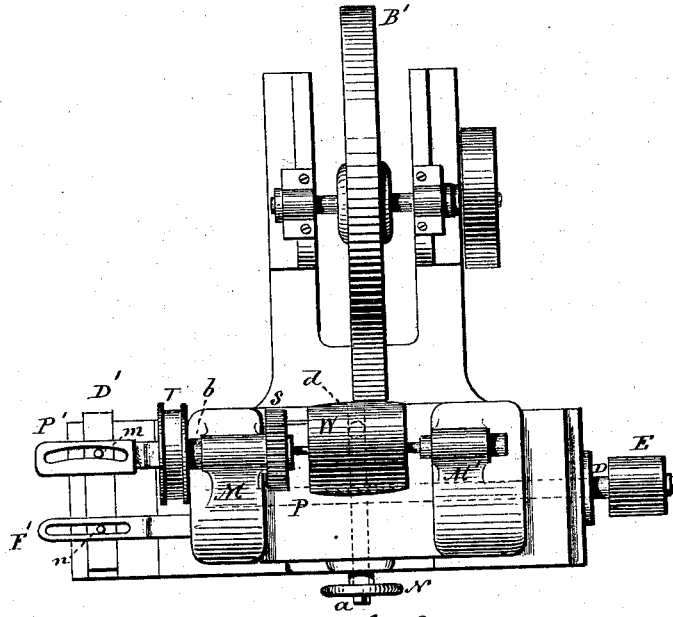
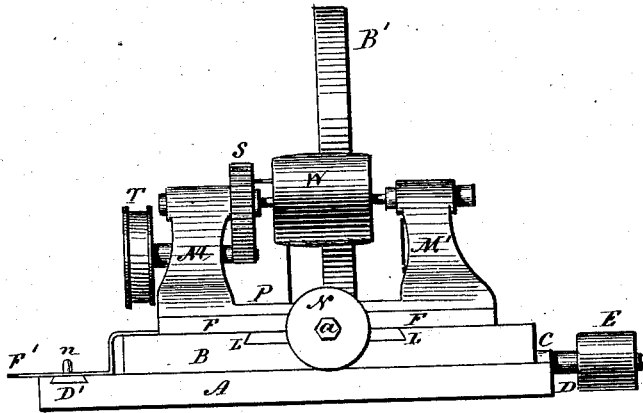

Fig. 2.



Witnesses.
J. H. Thurman
C. W. Forbick

Austin Wood
 Inventor.
 By Atty.
John O. Earl

A. WOOD.
Machine for Grinding Pulleys.

No. 164,897.

Patented June 22, 1875.

fig. 3

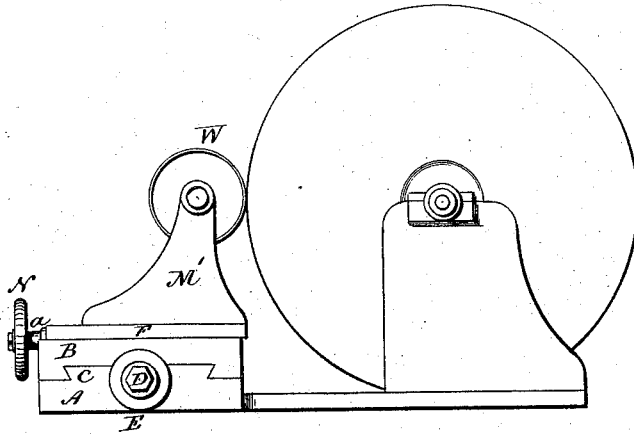
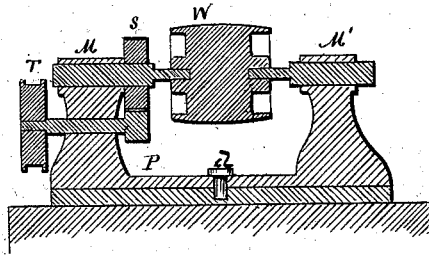

fig. 4



Witnesses.
J. H. Shumway
C. W. Forbes

Avin Wood
By Atty. Inventor
John S. Earls

UNITED STATES PATENT OFFICE.

AURIN WOOD, OF WORCESTER, MASSACHUSETTS.

IMPROVEMENT IN MACHINES FOR GRINDING PULLEYS.

Specification forming part of Letters Patent No. **161,897**, dated June 22, 1875; application filed December 5, 1874.

To all whom it may concern:

Be it known that I, AURIN WOOD, of Worcester, in the county of Worcester and State of Massachusetts, have invented a new Machine for Grinding Pulleys; and I do hereby declare the following, when taken in connection with the accompanying drawings and the letters of reference marked thereon, to be a full, clear, and exact description of the same, and which said drawings constitute part of this specification, and represent, in—

Figure 1, plan or top view; Fig. 2, front view; Fig. 3, end view; Fig. 4, transverse section.

This invention relates to a new method of finishing the surface of pulleys. The usual method has been to "turn" the surface in a common engine-lathe; but to do this the rim must be cast sufficiently thick, that the tool may take through the scale. Hence a large proportion of the rim is removed and wasted by this usual method. On pulleys of considerable size, or pulleys with light rims, the cutting must be very slow to prevent "chattering."

The object of this invention is to finish the surface by grinding; and the invention consists in a carriage for supporting the pulley, and in which it is made to revolve, the said carriage self-adjusting to the shape of the face of the pulley, combined with a revolving grinding wheel or stone running in contact with the face of the pulley, as more fully hereinafter described.

A is the bed, on which the base B of the carriage is arranged to move longitudinally upon suitable guides C, and caused to move to and fro on said guides by the leading-screw D, in like manner as for similar machines. A pulley, E, is attached to the said screw, so that power may be applied to turn the screw, if desired. On this base the carriage-body F is arranged to move in guides L transversely across the base B, caused so to do by a screw, a, to which a hand-wheel, N, is attached, as a convenience for turning said screw. On the body F a plate, P, is pivoted, as at d, so as to turn to the right and left upon said pivot d, but resting upon the body F. On this plate are two heads, M M', the one, M, supporting a mandrel, b, carrying a face-plate, S, which is

caused to revolve by the application of power thereto in any known manner, here represented as by a counter-shaft and pulley, T, geared to the said face-plate. The other head is provided with a center, substantially as the "tail-stock" of a lathe. Between the face-plate and the tail-stock the pulley W to be finished is arranged substantially as in a lathe, and so as to revolve with the face-plate. In rear of the pulley-carriage the grinding-wheel B' is arranged upon an axis substantially parallel to the axis of the pulley to be ground. This wheel or stone is made to revolve by the application of power thereto in the usual manner for such wheels. The pulley to be ground is arranged in the carriage, and adjusted so that the surface of the pulley and the grinding-pulley, both revolving, will come in contact, and in such contact the surface of the pulley will be ground and finished.

The surface of pulleys is usually made substantially segmental in longitudinal line—that is, of larger diameter in the center than at the ends. That this desired form may be given to the surface a transverse-sliding bar, D', is arranged in the bed, and this is connected to the body F by an arm, F', so that the transverse movement of the body and bar will be the same. The arm F' is slotted to set over a stud, n, on the bar D'. Hence the longitudinal movement of the carriage does not affect the bar, the slot in the bar passing freely over the stud from one extreme to the other. From the plate P a similar arm, P', extends over the bar D, the slot in this bar being substantially of the form of the longitudinal face of the pulley to be ground. This slot works upon a stud, m, on the bar D'. As this arm P' travels longitudinally with the carriage it follows that the plate P and the pulley being ground will, in such longitudinal movement, receive an oscillating transverse movement, according to the shape of the slot, and thus present the surface of the pulley from end to end to the stone to be ground and finished to that form.

By this method of finishing pulleys I am enabled to cast them with a very thin rim, and as the process of grinding requires less labor than that of turning I am enabled to finish the pulley for little, if any, more cost

than the amount of metal saved from the old process.

I claim—

The combination of a supporting-carriage for the pulley, having a longitudinal and transverse movement, and a pattern, P', to impart a predetermined oscillating movement

to the supports M M', and a grinding-wheel, B', the combination and arrangement being substantially such as described.

AURIN WOOD.

Witnesses:

JOSEPH A. HOWLAND,
OTIS WARREN.